



**MERCER  
RUBBER Co.**

350 Rabro Drive  
Hauppauge, NY 11788  
Tel 631-582-1524  
FAX 631-348-0279  
Info@Mercer-Rubber.com  
www.Mercer-Rubber.com

**FLANGED CONCENTRIC and  
ECCENTRIC  
REDUCING  
EXPANSION JOINTS with  
SPHERICAL ARCH**

**FCR500  
FER500**  
BULLETIN FR500-MR8

**FCR501 CONCENTRIC EXPANSION JOINT**

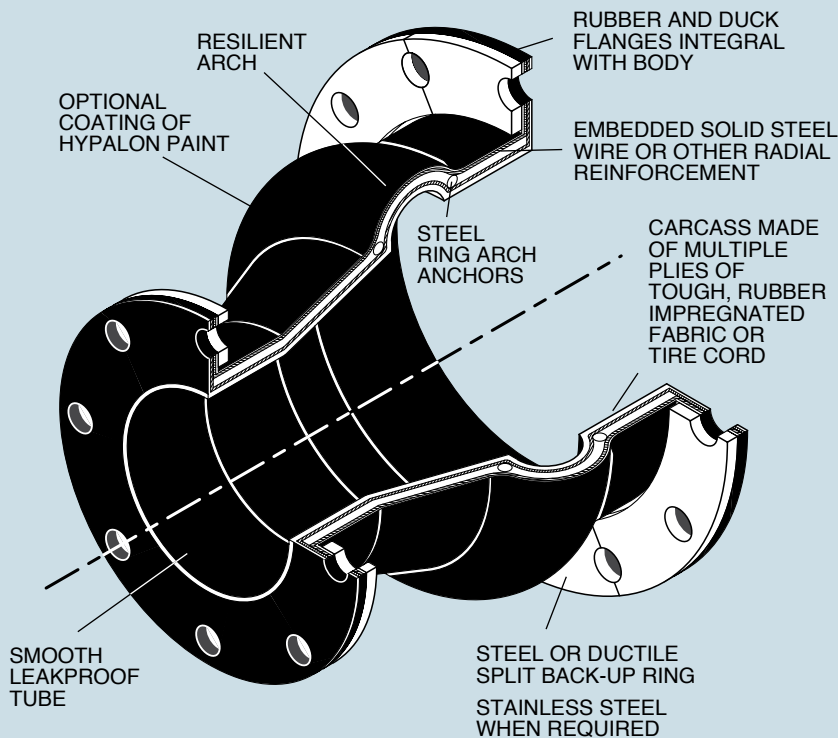

**FER501 ECCENTRIC EXPANSION JOINT**

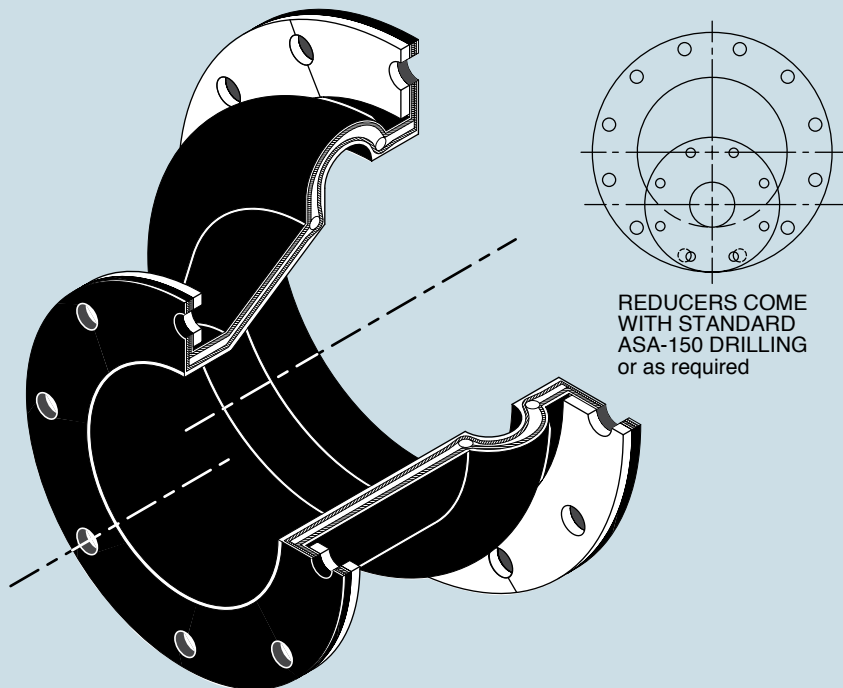

Expansion joints installed in piping systems must be anchored on both sides of the joints to avoid the use of control rods. If control rods are installed as a safety measure, the locking nuts must be backed off with a clearance equal to the specified axial movement. The expansion joint will exert thrust on the anchors. To calculate thrust, use the following equation:

$$\text{Thrust} = (\text{Thrust Area Large End ID}) \times (\text{Rated Working Pressure})$$

EXAMPLE—

For a 12" x 10" FCR/FER500, the Thrust Area 133 in<sup>2</sup> multiplied by the Rated Working Pressure 140 psi equals the Thrust 18,620 lbs.

$$133 \times 140 = 18,620 \text{ lbs.}$$

Expansion joints installed in unanchored piping or connected to isolated equipment must have control rods. Once control rods are installed the joint will no longer act as an expansion joint, since the pressure will force the joint against the control rod stops. It will allow for misalignment, transverse and possibly angular motion. The nuts of the control rods should be threaded tight to control rod gussets at the published length.

Initial misalignment should be kept to a maximum of 1/8".

Expansion joint flanges must be in contact with a flat surface, or a maximum 1/16" standard raised face. Depressions or protrusions typical of vitaulic or similar type flanges must be covered with a steel spacer flange first. Rubber flanges will not retain loose elements in valve bodies that rely on contact with a steel flange. In these applications, a steel spacer flange must be inserted between the rubber expansion joint and the valve body.

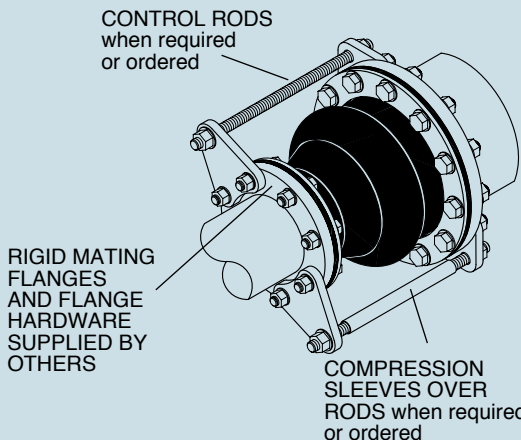

**Series FER500 Dimensions, Allowable Movements & Pressures**

DIMENSIONS			MOVEMENTS AND PRESSURES							
FER Size (Large End x Small End)	FF Length (inches)		Axial Compression (inches)	Axial Extension (inches)	Lateral Deflection (±inches)	Angular Movement (degrees)	Torsional Movement (degrees)	Rated Working Pressure (psig)	Vacuum Rating (in Hg)	*Thrust Area (sq. inches)
	Minimum	Maximum								
2 x 11/2	8	18	7/8	1/2	1/2	14.5	3	170	30	7
2 1/2 x 11/2	8	18	7/8	1/2	1/2	11.5	3	170	30	10
2 1/2 x 2	8	18	7/8	1/2	1/2	11.5	3	170	30	10
3 x 1	10	18	1	5/8	5/8	10.0	3	170	30	13
3 x 1 1/2	8	10	1	5/8	5/8	10.0	3	170	30	13
3 x 2	8	18	1	5/8	5/8	10.0	3	170	30	13
3 x 2 1/2	8	18	1	5/8	5/8	10.0	3	170	30	13
4 x 1 1/2	10	18	1	5/8	5/8	10.0	3	170	30	20
4 x 2	8	12	1	5/8	5/8	7.5	3	170	30	20
4 x 2 1/2	8	18	1	5/8	5/8	7.5	3	170	30	20
4 x 3	8	18	1	5/8	5/8	7.5	3	170	30	20
5 x 3	8	18	1	5/8	5/8	6.0	3	140	30	28
5 x 4	8	18	1	5/8	5/8	6.0	3	140	30	28
6 x 2	14	20	1	5/8	5/8	5.5	3	140	30	38
6 x 2 1/2	10	18	1	5/8	5/8	5.5	3	140	30	38
6 x 3	10	18	1	5/8	5/8	5.5	3	140	30	38
6 x 4	10	18	1	5/8	5/8	5.5	3	140	30	38
6 x 5	10	18	1	5/8	5/8	5.5	3	140	30	38
8 x 4	14	18	1	5/8	5/8	5.0	3	140	30	64
8 x 5	10	18	1	5/8	5/8	5.0	3	140	30	64
8 x 6	10	18	1	5/8	5/8	5.0	3	140	30	64
10 x 4	16	24	1	5/8	5/8	4.5	3	140	30	95
10 x 5	14	18	1	5/8	5/8	4.5	3	140	30	95
10 x 6	10	18	1	5/8	5/8	4.5	3	140	30	95
10 x 8	10	18	1	5/8	5/8	4.5	3	140	30	95
12 x 4	16	18	1	5/8	5/8	3.8	3	140	30	133
12 x 6	16	24	1	5/8	5/8	3.8	3	140	30	133
12 x 8	10	18	1	5/8	5/8	3.8	3	140	30	133
12 x 10	10	18	1	5/8	5/8	3.8	3	140	30	133
14 x 8	16	24	13/8	7/8	7/8	3.3	2	90	30	183
14 x 10	10	18	13/8	7/8	7/8	3.3	2	90	30	183
14 x 12	10	18	13/8	7/8	7/8	3.3	2	90	30	183
16 x 8	12	18	13/8	7/8	7/8	2.8	2	70	30	234
16 x 10	16	18	13/8	7/8	7/8	2.8	2	70	30	234
16 x 12	12	18	13/8	7/8	7/8	2.8	2	70	30	234
16 x 14	12	18	13/8	7/8	7/8	2.8	2	70	30	234
18 x 10	20	25	13/8	7/8	7/8	2.5	1	70	30	291
18 x 12	20	25	13/8	7/8	7/8	2.5	1	70	30	291
18 x 14	14	18	13/8	7/8	7/8	2.5	1	70	30	291
18 x 16	14	18	13/8	7/8	7/8	2.5	1	70	30	291
20 x 10	26	30	13/8	7/8	7/8	2.5	1	70	30	354
20 x 12	26	30	13/8	7/8	7/8	2.5	1	70	30	354
20 x 14	16	24	13/8	7/8	7/8	2.5	1	70	30	354
20 x 16	16	24	13/8	7/8	7/8	2.5	1	70	30	354
20 x 18	16	24	13/8	7/8	7/8	2.5	1	70	30	354
22 x 20	18	24	13/8	7/8	7/8	2.3	1	70	30	424
24 x 10	22	30	15/8	1	1	2.0	1	70	30	510
24 x 14	26	30	15/8	1	1	2.0	1	70	30	510
24 x 16	26	30	15/8	1	1	2.0	1	70	30	510
24 x 18	16	24	15/8	1	1	2.0	1	70	30	510
24 x 20	16	24	15/8	1	1	2.0	1	70	30	510
26 x 24	14	18	15/8	1	1	2.0	1	70	30	594
30 x 20	16	24	15/8	1	1	2.0	1	60	30	779
30 x 24	16	24	15/8	1	1	2.0	1	60	30	779
30 x 28	16	28	15/8	1	1	2.0	1	60	30	779
36 x 20	18	30	15/8	1	1	1.5	1	60	30	1104
36 x 24	18	30	15/8	1	1	1.5	1	60	30	1104
36 x 30	14	30	15/8	1	1	1.5	1	60	30	1104
42 x 36	18	24	15/8	1	1	1.5	1	60	30	1485
54 x 48	18	24	15/8	1	1	1.3	1	60	30	2418

\* Based on large end ID. All dimensions and movements are in inches, unless specified.  
For pipe sizes and lengths not mentioned, please contact our Area Sales Representative or our NY Office.

Series FCR500 Dimensions, Allowable Movements & Pressures

DIMENSIONS			MOVEMENTS AND PRESSURES							
FCR Size (Large End x Small End)	FF Length (inches)		Axial Compression (inches)	Axial Extension (inches)	Lateral Deflection (±inches)	Angular Movement (degrees)	Torsional Movement (degrees)	Rated Working Pressure (psig)	Vacuum Rating (in Hg)	*Thrust Area (sq. inches)
	Minimum	Maximum								
2 x 1	6	18	7/8	1/2	1/2	14.5	3	170	30	7
2 x 1 1/4	6	18	7/8	1/2	1/2	14.5	3	170	30	7
2 x 1 1/2	6	18	7/8	1/2	1/2	14.5	3	170	30	7
3 x 1	9	18	1	5/8	5/8	10.0	3	170	30	13
3 x 1 1/2	6	18	1	5/8	5/8	10.0	3	170	30	13
3 x 2	8	18	1	5/8	5/8	10.0	3	170	30	13
3 x 2 1/2	8	18	1	5/8	5/8	10.0	3	170	30	13
3 1/2 x 3	7	18	1	5/8	5/8	10.0	3	170	30	16
4 x 1 1/2	8	16	1	5/8	5/8	10.0	3	170	30	20
4 x 2	7	18	1	5/8	5/8	7.5	3	170	30	20
4 x 3	7	18	1	5/8	5/8	7.5	3	170	30	20
4 x 3 1/2	7	18	1	5/8	5/8	7.5	3	170	30	20
5 x 2	9	18	1	5/8	5/8	6.0	3	140	30	28
5 x 2 1/2	9	18	1	5/8	5/8	6.0	3	140	30	28
5 x 3	7	18	1	5/8	5/8	6.0	3	140	30	28
5 x 4	7	18	1	5/8	5/8	6.0	3	140	30	28
6 x 2	9	18	1	5/8	5/8	5.5	3	140	30	38
6 x 2 1/2	12	15	1	5/8	5/8	5.5	3	140	30	38
6 x 3	8	18	1	5/8	5/8	5.5	3	140	30	38
6 x 4	7	18	1	5/8	5/8	5.5	3	140	30	38
6 x 5	7	15	1	5/8	5/8	5.5	3	140	30	38
8 x 3	9	18	1	5/8	5/8	5.0	3	140	30	64
8 x 4	9	18	1	5/8	5/8	5.0	3	140	30	64
8 x 5	8	14	1	5/8	5/8	5.0	3	140	30	64
8 x 6	7	17	1	5/8	5/8	5.0	3	140	30	64
10 x 4	9	18	1	5/8	5/8	4.5	3	140	30	95
10 x 5	9	18	1	5/8	5/8	4.5	3	140	30	95
10 x 6	9	18	1	5/8	5/8	4.5	3	140	30	95
10 x 8	9	16	1	5/8	5/8	4.5	3	140	30	95
12 x 5	9	18	1	5/8	5/8	3.8	3	140	30	133
12 x 6	10	18	1	5/8	5/8	3.8	3	140	30	133
12 x 8	10	18	1	5/8	5/8	3.8	3	140	30	133
12 x 10	8	18	1	5/8	5/8	3.8	3	140	30	133
14 x 8	12	19	13/8	7/8	7/8	3.3	2	90	30	183
14 x 10	9	24	13/8	7/8	7/8	3.3	2	90	30	183
16 x 5	16	24	13/8	7/8	7/8	2.8	2	70	30	234
16 x 8	13	18	13/8	7/8	7/8	2.8	2	70	30	234
16 x 10	13	18	13/8	7/8	7/8	2.8	2	70	30	234
16 x 12	10	18	13/8	7/8	7/8	2.8	2	70	30	234
16 x 14	10	18	13/8	7/8	7/8	2.8	2	70	30	234
18 x 6	10	24	13/8	7/8	7/8	2.5	1	70	30	291
18 x 10	13	18	13/8	7/8	7/8	2.5	1	70	30	291
18 x 12	12	18	13/8	7/8	7/8	2.5	1	70	30	291
18 x 14	10	24	13/8	7/8	7/8	2.5	1	70	30	291
18 x 16	12	18	13/8	7/8	7/8	2.5	1	70	30	291
20 x 12	11	24	13/8	7/8	7/8	2.5	1	70	30	354
20 x 14	12	18	13/8	7/8	7/8	2.5	1	70	30	354
20 x 16	10	18	13/8	7/8	7/8	2.5	1	70	30	354
20 x 18	10	18	13/8	7/8	7/8	2.5	1	70	30	354
22 x 20	8	24	13/8	7/8	7/8	2.3	1	70	30	424
24 x 10	14	24	15/8	1	1	2.0	1	70	30	510
24 x 12	12	24	15/8	1	1	2.0	1	70	30	510
24 x 14	18	24	15/8	1	1	2.0	1	70	30	510
24 x 16	17	30	15/8	1	1	2.0	1	70	30	510
24 x 18	13	25	15/8	1	1	2.0	1	70	30	510
24 x 20	10	18	15/8	1	1	2.0	1	70	30	510
26 x 20	18	19	15/8	1	1	2.0	1	70	30	594
28 x 20	12	22	15/8	1	1	2.0	1	60	30	779
28 x 24	9	20	15/8	1	1	2.0	1	60	30	779
28 x 26	14	18	15/8	1	1	2.0	1	60	30	779
30 x 20	12	18	15/8	1	1	2.0	1	60	30	779
30 x 24	12	24	15/8	1	1	2.0	1	60	30	779

\* Based on large end ID. All dimensions and movements are in inches, unless specified.

Continued on next page.

For pipe sizes and lengths not mentioned, please contact our Area Sales Representative or our NY Office.

**Series FCR500 Dimensions, Allowable Movements & Pressures**

DIMENSIONS			MOVEMENTS AND PRESSURES							
FCR Size (Large End x Small End)	FF Length (inches)		Axial Compression (inches)	Axial Extension (inches)	Lateral Deflection (±inches)	Angular Movement (degrees)	Torsional Movement (degrees)	Rated Working Pressure (psig)	Vacuum Rating (in Hg)	*Thrust Area (sq. inches)
	Minimum	Maximum								
32 x 26	10	18	15/8	1	1	2.0	1	60	30	881
32 x 28	10	18	15/8	1	1	2.0	1	60	30	881
36 x 20	14	18	15/8	1	1	1.5	1	60	30	1104
36 x 30	10	18	15/8	1	1	1.5	1	60	30	1104
42 x 30	18	24	15/8	1	1	1.5	1	60	30	1485
42 x 36	14	24	15/8	1	1	1.5	1	60	30	1485
42 x 38	12	24	15/8	1	1	1.5	1	60	30	1485
48 x 36	12	16	15/8	1	1	1.3	1	60	30	1924
48 x 40	18	19	15/8	1	1	1.3	1	60	30	1924
48 x 42	15	18	15/8	1	1	1.3	1	60	30	1924
50 x 44	15	18	15/8	1	1	1.3	1	60	30	2083
54 x 36	15	30	15/8	1	1	1.0	1	60	30	2418
54 x 42	18	19	15/8	1	1	1.0	1	60	30	2418
54 x 48	15	28	15/8	1	1	1.0	1	60	30	2418
60 x 48	15	24	15/8	1	1	1.0	1	50	30	2970
72 x 66	15	18	15/8	1	1	1.0	1	45	30	4243

\* Based on large end ID. All dimensions and movements are in inches, unless specified.  
For pipe sizes and lengths not mentioned, please contact our Area Sales Representative or our NY Office.

150# DRILLING INFORMATION (inches)				
Pipe Size	Flange OD	Bolt Circle Dia.	No. of Bolts	Bolt Hole Dia.
1	4 1/4	3 1/8	4	5/8
1 1/4	4 5/8	3 1/2	4	5/8
1 1/2	5	3 7/8	4	5/8
2	6	4 3/4	4	3/4
2 1/2	7	5 1/2	4	3/4
3	7 1/2	6	4	3/4
3 1/2	8 1/2	7	8	3/4
4	9	7 1/2	8	3/4
5	10	8 1/2	8	7/8
6	11	9 1/2	8	7/8
8	13 1/2	11 3/4	8	7/8
10	16	14 1/4	12	1
12	19	17	12	1
14	21	18 3/4	12	1 1/4
16	23 1/2	21 1/4	16	1 1/4
18	25	22 3/4	16	1 1/4
20	27 1/2	25	20	1 1/4
22	29 1/2	27 1/4	20	1 3/8
24	32	29 1/2	20	1 3/8
26	34 1/4	31 3/4	24	1 3/8
28	36 1/2	34	28	1 3/8
30	38 3/4	36	28	1 3/8
32	41 3/4	38 1/2	28	1 5/8
34	43 3/4	40 1/2	32	1 5/8
36	46	42 3/4	32	1 5/8
40	50 3/4	47 1/4	36	1 5/8
42	53	49 1/2	36	1 5/8
44	55 1/4	51 3/4	40	1 5/8
48	59 1/2	56	44	1 5/8
50	61 3/4	58 1/4	44	1 7/8
54	66 1/4	62 3/4	44	1 7/8
56	68 3/4	65	48	1 7/8
60	73	69 1/4	52	2
66	80	76	52	2
72	86 1/2	82 1/2	60	2

FCR500 & FER500			
Material Availability & Operating Temperatures			
FCR500 FER500	STANDARD MATERIALS**		Max Oper. Temp.
	Tube	Cover	
B	Butyl	Butyl	250°F
E	EPDM	EPDM	250°F
H	Hypalon	Hypalon	225°F
HN	Hypalon	Neoprene	225°F
N	Neoprene	Neoprene	225°F
NH	Neoprene	Hypalon	225°F
Ni	Nitrile	Nitrile	210°F
NiN	Nitrile	Neoprene	210°F
NR	Neoprene	Natural	225°F
R	Natural	Natural	180°F
RN	Natural	Neoprene	180°F
V	Viton®	Viton®	250°F
Kevlar Reinforced HTFCR500 & HTFER500			
Material Availability & Operating Temperatures			
HTFCR500 HTFER500	HIGH TEMPERATURE MATERIAL		Max Oper. Temp.
	Cover		
K-E	EPDM		350°F
K-V	Viton®		400°F

\*\*Food Grade Rubber Available.



**MERCER RUBBER Co.**

350 Rabro Drive • Hauppauge, NY 11788 • Tel 631-582-1524 • FAX 631-348-0279

Email [Info@Mercer-Rubber.com](mailto:Info@Mercer-Rubber.com) • [www.Mercer-Rubber.com](http://www.Mercer-Rubber.com)